

DOT MATRIX PRINTER MECHANISM

MP512N-24-A

SPECIFICATION MANUAL

REV. No. 0.02



The patent ownership of the circuits and control examples noted in this manual have not been investigated. Thorough searches regarding the industrial patent ownership should be performed before using these circuits and control examples.

NOTICE

- All rights reserved. Reproduction of any part of this manual in any form whatsoever, without STAR's express permission is forbidden.
- The contents of this manual are subject to change without notice.
- All efforts have been made to ensure the accuracy of the contents of this manual at the time of going to press. However, should any errors be detected, STAR would greatly appreciate being informed of them.
- The above notwithstanding, STAR can assume no responsibility for any errors in this manual.

Contents

1. GENERAL DESCRIPTION	2
2. STRUCTURE	3
2.1 Configuration	3
2.2 Theory of Operation	3
3. BASIC SPECIFICATIONS	4
3.1 Printing Specifications	4
3.2 Printing Speed	4
3.3 Recording Paper	4
3.4 Ribbon Cassette	4
3.5 Power Voltage	5
3.6 Connectors	5
3.7 External Dimensions and Mass	5
3.8 Operating Environment	6
3.9 Storage Environment	7
3.10 Reliability Specifications	7
4. DETAILED SPECIFICATIONS	8
4.1 Recording Paper	8
4.2 Printing Configuration	9
4.3 Print Head	11
4.4 Carriage Characteristics	15
4.5 Home Position Detector	20
4.6 Timing Sequence	24
4.7 Connector Wiring Diagram	26
4.8 Ribbon Cassette Specifications	28
4.9 Setting the Head Gap	29
5. PRECAUTIONS WHEN MOUNTING THE PRINTER	30
5.1 Printer External Dimensions and Mounting the Printer	30
5.2 Space for Mounting Removing the Ribbon Cassette	30
5.3 Head Vicinity	32
5.4 Precautions for Designing the Paper Path	32
5.5 Precautions When Controlling the Printer	33
6. OTHER PRECAUTIONS	34

1. GENERAL DESCRIPTION

This product does not include any paper feed mechanism or platen.

How to View Models

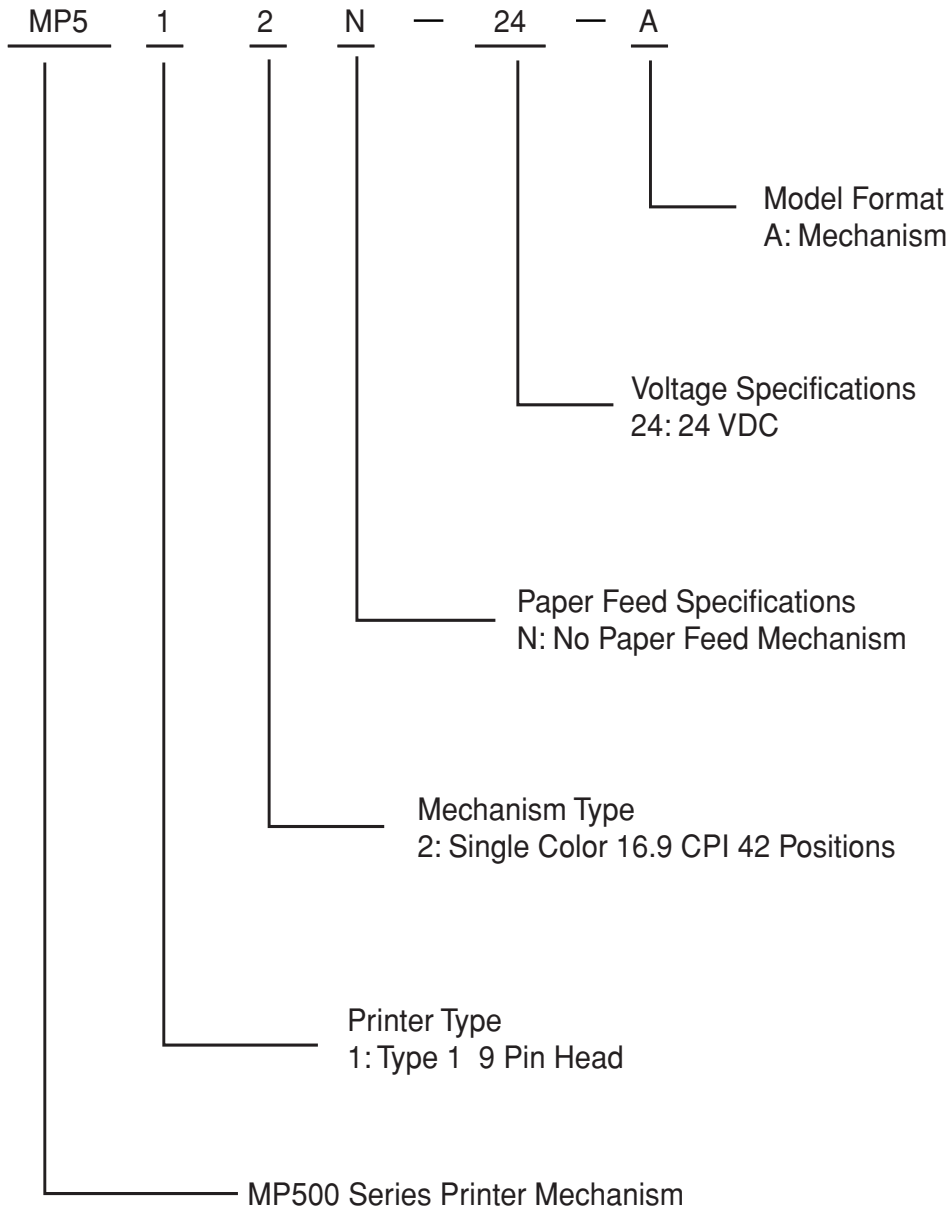

2. STRUCTURE

2.1 Configuration

The printer mechanism is configured of the following apparatuses.

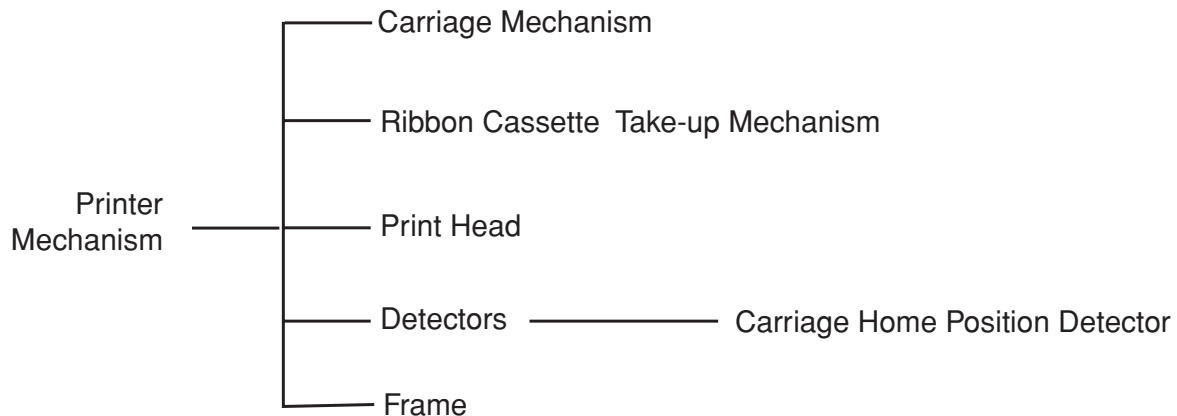

2.2 Theory of Operation

1) Print Head Transport

Drive from the rotation of the carriage motor is transmitted to the drive shaft via deceleration gears. The carriage moves horizontally along cam grooves disposed in the drive shaft. Reciprocal horizontal carriage movement is attained by forward and reverse rotation of the carriage motor (which is a stepping motor).

The print head is fastened to the top of the carriage so it moves reciprocally unitized to the carriage.

2) Print Timing

Printing is performed by being synchronized to the phase switching signal of the carriage motor.

3) Ribbon Take-up

The ribbon take-up mechanism is interlocked to the carriage motor to receive its drive. A one-way method, which employs a ratchet mechanism is used to convert the forward and reverse rotation of the carriage motor to the same rotation.

The ribbon is taken up when the carriage is transported from the right to the left and rotates freely when transported from the left to the right so no ribbon is taken up.

4) Paper Feed Mechanism

Users must prepare the paper feed mechanism and the platen.

3. BASIC SPECIFICATIONS

3.1 Printing Specifications

- 1) Printing Method: Serial impact dot matrix method
- 2) Print Head: 9 pin (wire diameter 0.3 mm)
- 3) Printing Direction: Bi-directional left and right (Logic seeking)
- 4) Printing Format: 42 positions (7 x 9 font, no space between characters)
- 5) Printing Configuration:
 - Character Configuration 7 (Half) x 9 dots
 - Character Pitch 1.5 mm (when using 7 x 9)
 - Character Dimensions 1.2 mm x 2.42 mm (W x H)
 - Dot Spacing 0.30 mm (in the horizontal direction)
0.353 mm (in the vertical direction)
- 6) Total Dot Count: 210 Dots (420 positions) per line
- 7) Printing Region: 63 mm
- 8) Carriage Operating Pitch: 0.3 mm per full step
0.15 mm per half step

3.2 Printing Speed

When using 76 mm paper: Maximum 4.0 lines per second (42 columns of continuous printing)

3.3 Recording Paper

Thickness: Normal roll paper (1 ply): 0.07 to 0.10 mm
Copies: Original + 2 copies (Max. 0.2 mm)

3.4 Ribbon Cassette

- 1) Recommended Ribbon Cassette: RC200B (Black)
- 2) Life: 1.2 million characters

3.5 Power Voltage

Drive Power Voltage: 24 VDC \pm 10%

- Note:**
- Drive power voltage applies to the carriage motor.
 - 24 -1.2/+2.4 VDC power is recommended for print head drive.

3.6 Connectors

- 1) Types: FFC/PFC Connectors
- 2) Models: Nippon FCI Co., Ltd.: HLEM 28 R-1
- 3) Specifications: 1.25 mm pitch, 28 poles

3.7 External Dimensions and Mass

- 1) External Dimensions: 111.4 mm (W) x 70.7 mm (D) x 53.3 mm (H)
- 2) Weight: 300 \pm 20 g

* **Note:** External dimensions and weight do not include the ribbon cassette.

3.8 Operating Environment

- 1) Temperature: 0 to +50°C
- 2) Humidity: 10 to 80% RH

However, there must be no condensation. Assumes 80% RH and 40°C.

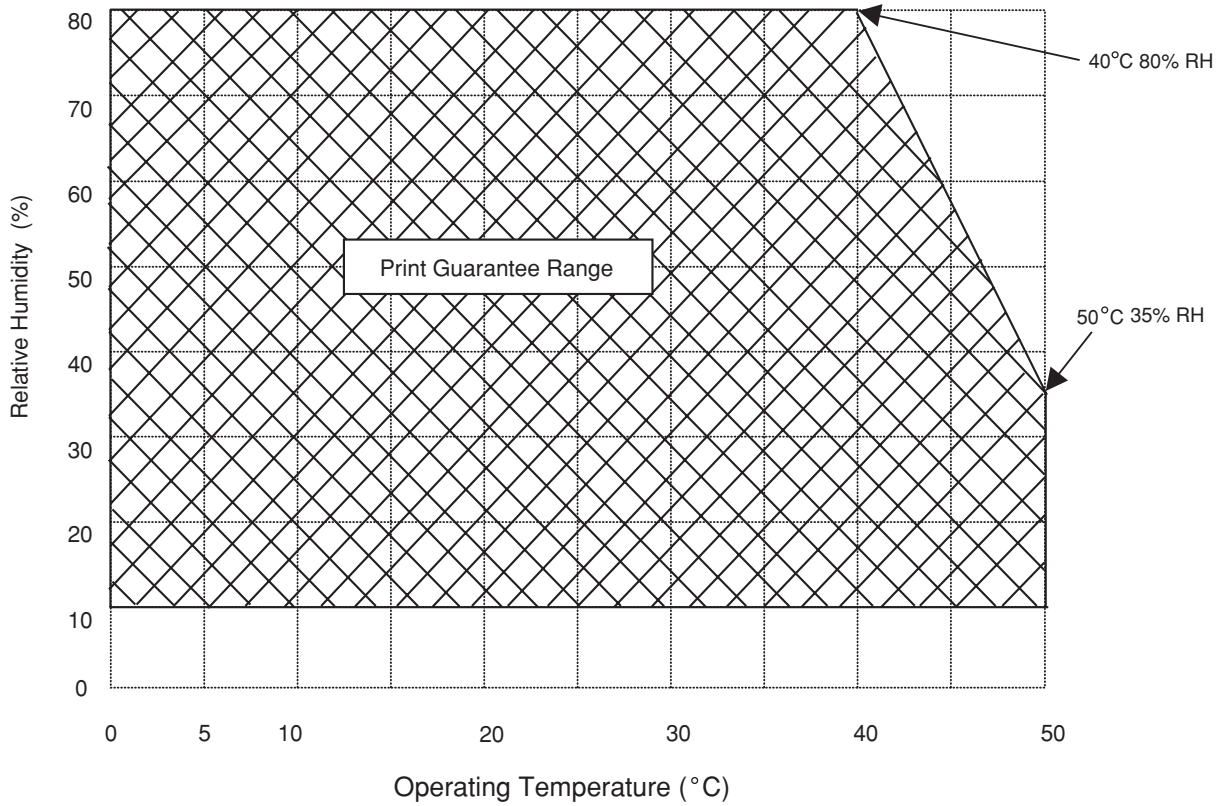

Fig. 3-1 Print Guarantee Range

3.9 Storage Environment

- 1) Temperature: -20 to +70°C
- 2) Humidity: 5 to 95% RH

The combination of 43°C and 95% RH (no condensation) is considered the worst values regarding high temperatures and humidity.

- 3) Vibration Tests: Vibration: 10 to 55 to 10 Hz
Amplitude: 1.54 mm (constant)
Sweep: 1 minute
Maximum G: 0.3 to 9.3 G
Direction: Three directions: X, Y, Z
Time: Two hours in each direction: Total 6 hours
Packing Status: Minimum Packing Status
- 4) Drop Tests: Height of Drop: 85 cm
Order of Drop: 1 angle; 3 corners; 6 surfaces
Packing Status: Minimum Packing Status

3.10 Reliability Specifications

- 1) Mechanism: Mechanical Life: 9 million lines

<Supplement>

Mechanical life is defined as the period at which failures from wear out is entered.

<Operating Conditions>

- Characters: Continuous printing of ASCII characters
- Character count: Bi-directional printing 42 positions per line.
- Recording Paper: Regular roll paper: 76 mm width, 0.085 mm thick
- Ribbon: Dedicated ribbon cassette RC200B
- 2) Impact Head: Life: 100 million characters
1 character configured by an average of 11.4 dots

4. DETAILED SPECIFICATIONS

4.1 Recording Paper

Types	Regular roll paper (1 ply)	Non-carbon roll paper (2 ply and 3 ply)	
Paper Thickness	0.07 to 0.10 mm	2 Ply	Original + 1 copy Max. total thickness of 0.14 mm combining 0.05 to 0.08 mm (thickness of one sheet) Recommended Paper: <ul style="list-style-type: none"> • Type: Mitsubishi NCR paper super • Paper Thickness: Upper paper N40 (paper thickness 0.06 mm) Bottom paper N60 (paper thickness 0.08 mm)
		3 Ply	Original 2 copies Max. total thickness of 0.2 mm combining 0.05 to 0.08 mm (thickness of one sheet) Recommended Paper: <ul style="list-style-type: none"> • Types: Mitsubishi NCR paper super • Paper Thickness: Upper paper N40 (paper thickness 0.06 mm) Middle paper N40 (paper thickness 0.06 mm) Bottom paper N60 (paper thickness 0.08 mm)

Note: There is the possibility of problems occurring, depending on the type of paper used.
Therefore, only use the recommended paper type.

4.2 Printing Configuration

1) Character Dimensions

1	Character Fonts (H x V)	7 x 9 (Half)	5 x 9
2	CPI	16.9	14.1
3	Printing Positions	42	35
4	Position Gaps (mm)	1.5	1.8
5	Character Dimensions		
	Width (mm)	1.20	1.50
	Height (mm)	2.42	2.42
6	Dot Gaps		
	Horizontal (mm)	0.3	0.3
	Vertical (mm)	0.353	0.353
7	Total Dot Count	210	210
8	Printing Region	63	63

2) Character Dimensions (2 Byte Characters: Character space is 1 dot.)

1	Character Fonts (H x V)	16 x 16 (Half)	8 x 16
2	CPI	9.41	9.41
3	Printing Positions	23	23
4	Position Gaps (mm)	2.7	2.7
5	Character Dimensions		
	Width (mm)	2.55	2.55
	Height V (mm)	2.95	2.95
6	Dot Gaps		
	Horizontal (mm)	0.15	0.3
	Vertical (mm)	0.176	0.176
7	Total Dot Count	207	207
8	Printing Region	62.1	62.1

3) Character Configuration

7 x 9 (Half) Fonts

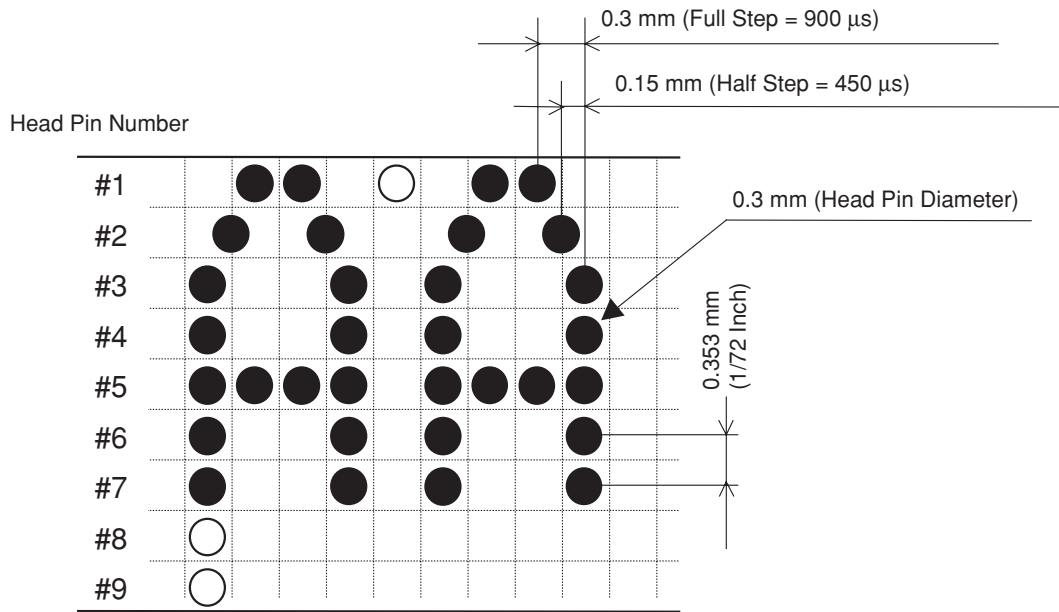

Note: Minimum cycle on the same pin is 900 μs.

Fig. 4-1 Character Configuration

Kanji Font (For Reference)

2 Byte: 16 x 16

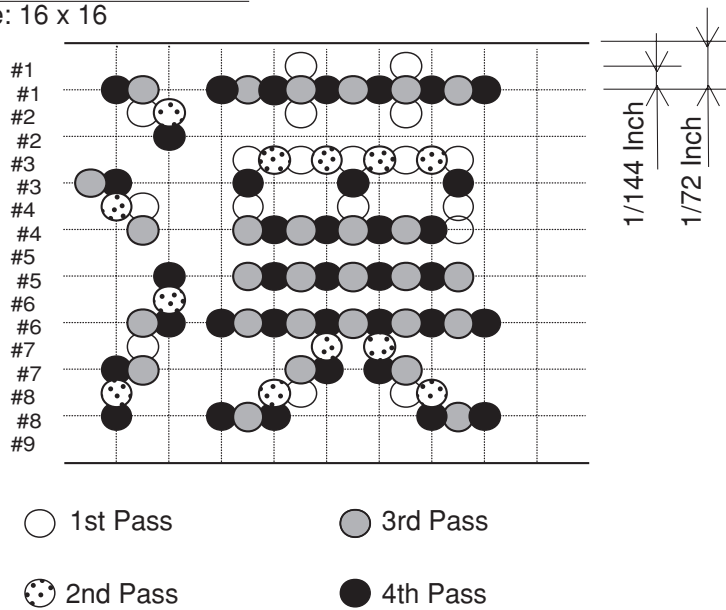

Fig. 4-2 Character Configuration

4.3 Print Head

4.3.1 Basic Specifications

- 1) Drive Method: Rated Voltage Drive
- 2) Power Voltage: DC 24 V \pm 2.4 V (Recommended DC 24 V -1.2V / +2.4V)
- 3) Response Frequency: Max. 1110 Hz
- 4) Energizing Time: See Fig. 4-4
- 5) Coil Resistance: 14.7 \pm 0.4 Ω (Includes cable resistance)
- 6) Peak Current: 1.0 A (When power voltage is 24 V and energizing time is 364 μ s.)
Max. 1.1 A (When power voltage is 26.4 V and energizing time is 334 μ s.)

4.3.2 Energizing Timing

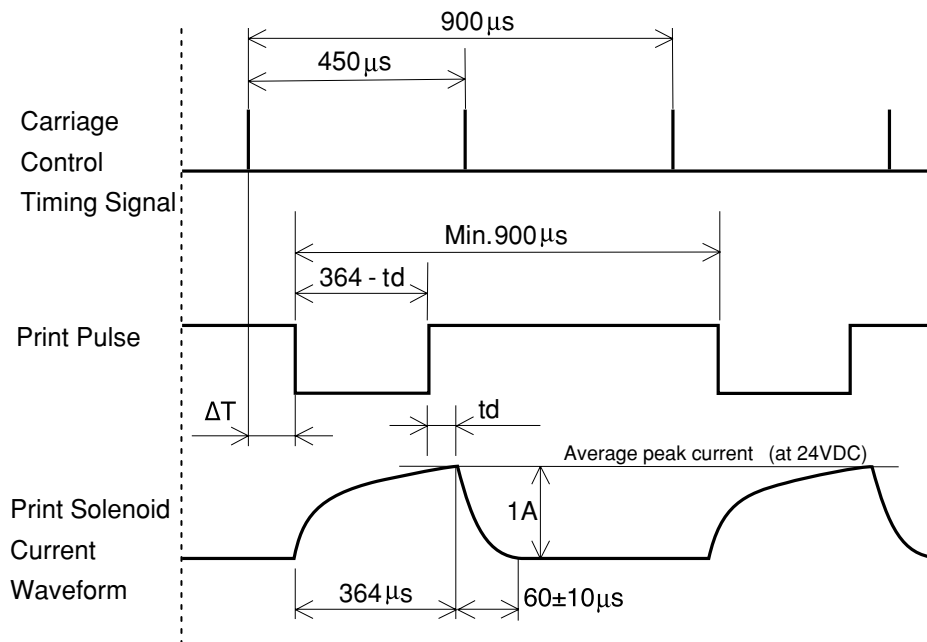

t_d : Transistor turn off delay time = 2 μ s

ΔT : Delay time for bidirectional printing

Fig. 4-3 Energizing Timing

4.3.3 Voltage Correction When Energizing

When the input voltage varies, the energy supplied to the head also changes. In such cases, it is necessary to correct the energizing time according to the voltage to attain stable print quality.

Adjust the energizing time according to the following conditions.

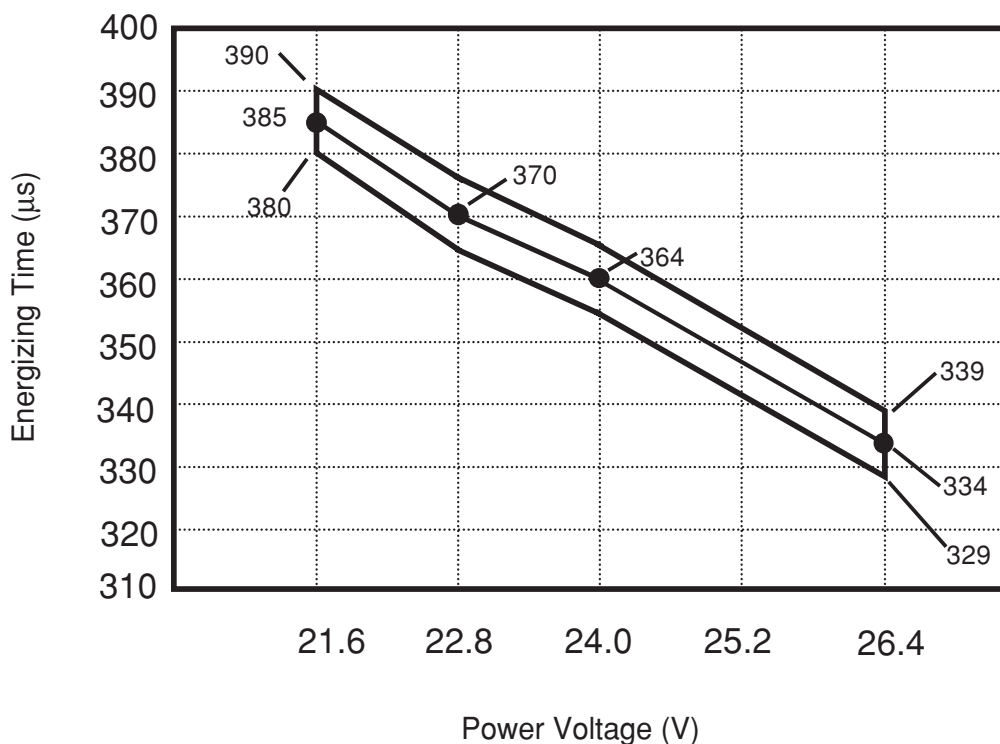

Fig. 4-4 Head Energizing Time - Head Power Supply

- Note:**
- Set the offset error for energizing time to within $\pm 5 \mu\text{s}$ of the central value.
 - Regulate the energizing time to $390 \mu\text{s}$ using a delimiter.

4.3.4 Temperature Control

This head is equipped with a head temperature sensor (thermistor). The thermistor controls the following according to the temperature it detects. Printing when above the established temperature will cause printer failure.

- 1) Temperature detection sensor (thermistor): Mitsubishi Materials: GA13-6H503JB
- 2) Control temperature:
 - T1 to $110 \text{ }^\circ\text{C}$ (Thermistor resistance value: $2.846 \text{ k}\Omega$)
 - T2 to $120 \text{ }^\circ\text{C}$ (Thermistor resistance value: $2.182 \text{ k}\Omega$)

3) Method of control

A: When using bi-directional printing

Head temperature less than or equal to T1:

Bi-directional printing

T2 greater than or equal to head temperature greater T1:

The time for stopping to switch carriage traveling direction when in bi-directional printing mode, is 230 ms.

Head temperature greater than T2:

Print stop

B: When using uni-directional printing

Head temperature less than or equal to T2:

Uni-directional printing

Head temperature greater than T2:

Print stop

4.3.5 Pre-fire

This action causes minute vibrations to the wires as a print warm up to improve the working of the wires.

Use pre-fires under the following conditions. Although the energizing time is short and does not last to the actual printing, pre-fire while moving the carriage to prevent the unlikely occurrence of mis-printing.

- 1) Operating Period: At power ON
- 2) Number of times: 210 times
- 3) Frequency: 900 Hz
- 4) Power Voltage: 24 VDC \pm 2.4V
- 5) Energizing Time: 160 \pm 5 μ s

4.3.6 Print Solenoid Drive Circuit Example

Use a zener diode to check the voltage spike that appears when turning the transistor OFF. Use the following transistor equipped with a zener diode (zener voltage 60 +10 V/-5 V) between the base and emitter, for the recommended circuits.

Symbols	Part Names and Quantity
TR1	2SC5832 (Sanyo)
R1	2.2kΩ
R2	330Ω
VH	23V+TR1 for Vce(sat)=24V

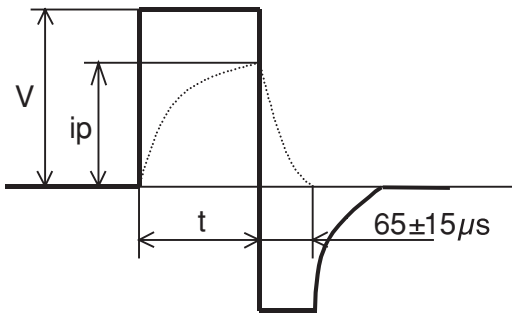
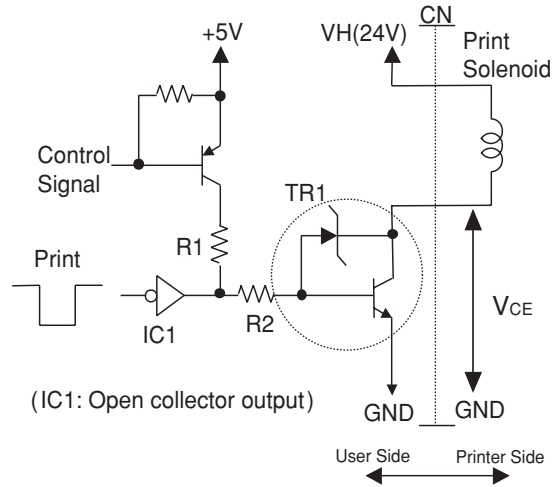

V: Voltage Coil Terminals
 ip: Current Peak Value
 t: Energized Time

Waveform Between Coil Terminals

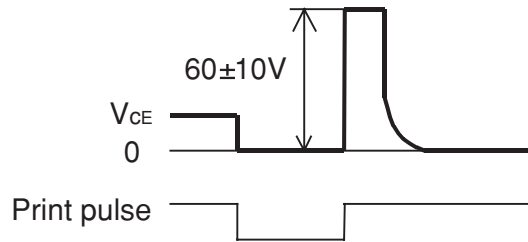

* The print solenoid energizing time Vce actually does not become 0V because of saturation voltage (0.5 V to 1.0 V).

Transistor Collector-Emitter waveform

Fig. 4-5 Drive Circuit Example

4.4 Carriage Characteristics

4.4.1 Carriage Transport Characteristics

- 1) Carriage Transport Characteristics: Drive Shaft Method
- 2) Carriage Transport Pitch: 0.15 mm
(Distance of travel for half step of the carriage motor)
- 3) Carriage Transport Speed: 333 mm/sec (when driven at equivalent speed)
- 4) Carriage Transport Directions: Bi-directional left and right (Logic seeking)
- 5) Carriage Holding Force (Not Charged): Min 10 N (Min. 1020 gf)

4.4.2 Carriage Motor Characteristics

- 1) Carriage Motor Format: 4 Phase PM Type Bipolar Stepping Motor
- 2) Drive Method: Bipolar Constant Current Drive
- 3) Excitation Method: 1-2 Phase Excitation
- 4) Basic Step Angle: 15° (1 cycle 24 separations)
- 5) Coil Resistance: $16.0 \Omega/\text{Phase}$ (25°C)
- 6) Drive Voltage: $24 \text{ VDC} \pm 10\%$
- 7) Rotation Direction: CW, CCW
- 8) Drive Frequency: 2220 PPS (when printing)
- 9) Constant Current Slice Level: 0.485 A (when driving)
0.09 A (When holding)

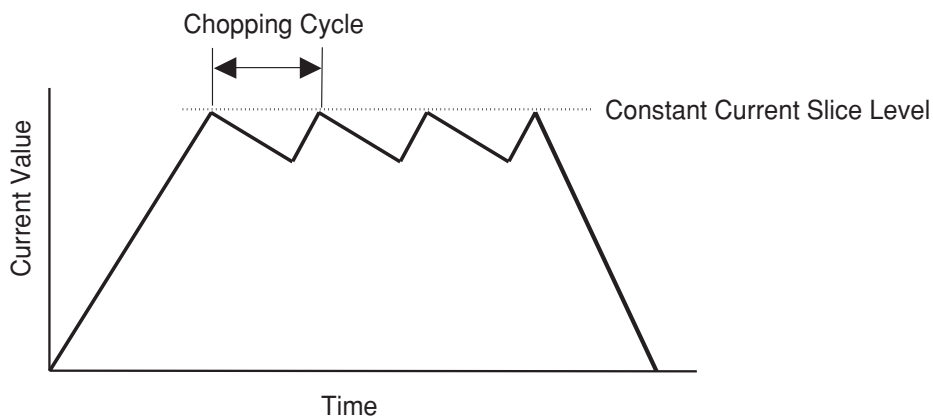

Fig. 4-6 Motor Current Waveform

10) Excitation Sequence

The carriage moves from the left edge to the right edge when the motor is excited in the steps of the following table. The motor rotates in the clockwise direction when viewed from the motor output shaft side.

Motor 1 step (half step) sends the carriage 0.15 mm. The pin numbers on the left of the table indicate the pin number of the connector for connections.

Step Pin No.	1	2	3	4	5	6	7	8
25 (A Phase)	H	H	H	L	L	L	L	L
26 (/A Phase)	L	L	L	L	H	H	H	L
27 (B Phase)	L	L	H	H	H	L	L	L
28 (/B Phase)	H	L	L	L	L	L	H	H

<Motor Control Method>

1) Motor Current Control

Controls the constant current slice level set to three levels, to hold down the motor heat while printing. See Fig. 4-7 Timing Chart for details regarding the current values.

2) Acceleration and Deceleration Control

It is necessary to control the acceleration of the motor to the constant speed area (maximum drive speed) to print from when the motor is stopped, and to control the deceleration of the motor from that constant speed area to a stopped state. The motor drive conditions in the are for acceleration control and deceleration control are controlled according to slow-up timer value and slow-down time value tables.

3) Drive Conditions When Printing

The motor should print only in the constant speed area. In either the acceleration and deceleration areas, dot pitches will be incorrect because the motor's rotating speed will not be consistent.

4) Startup Step

The same phase as the stopping step should be used to startup the motor from a stopped state. Startup up after energizing a constant current slice level of 0.485 A for 15 ms.

When continuously rotating the motor forward and reverse, use the same phase as the stopping step should shifted to the startup step up after energizing A for 15 ms.

5) Stopping Step

The same phase as the stopping step should be used to stop the motor. Energize a constant current slice level of 0.485 A for 15 ms.

6) Motor Excitation Method

The carriage motor drives with a 1-2 phase excitation. To prevent motor power swings, the startup step and the stopping step should be a 2 phase excitation.

7) Stopping

The same phase as the stopping step should be used in the stopped state. Maintain a constant current slice level 0.09 A.

4.4.3 Motor Drive Synch and Startup Method

1) Timing Chart

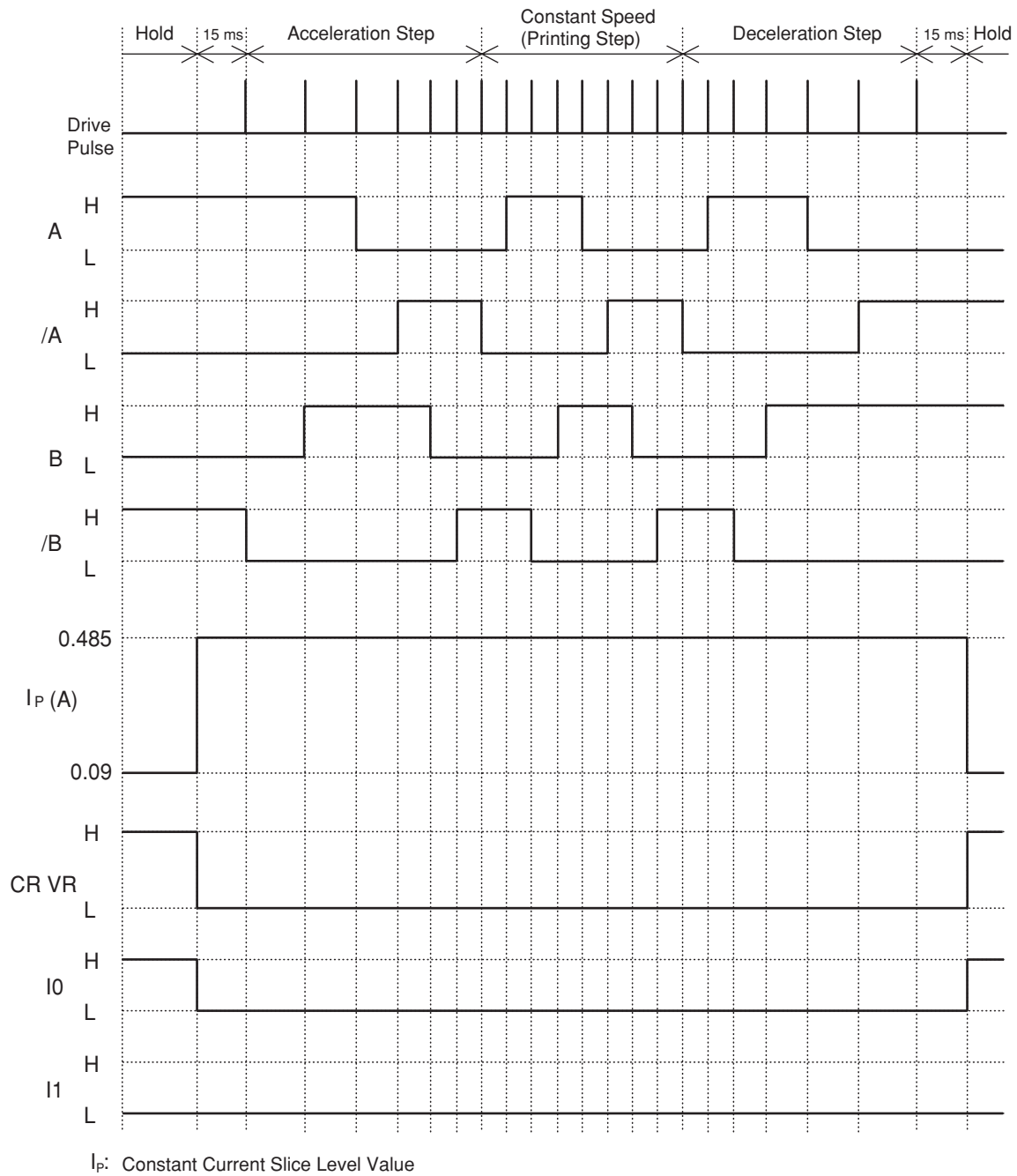

Fig. 4-7 Timing Chart

2) Drive Conditions

Slow-up Timer Value

No.	Timer (ms)	Pulse (pps)
1	2.500	400
2	1.818	550
3	1.429	700
4	1.176	850
5	1.053	950
6	0.952	1050
7	0.870	1150
8	0.800	1250
9	0.741	1350
10	0.690	1450
11	0.645	1550
12	0.610	1640
13	0.588	1700
14	0.568	1760
15	0.532	1820
16	0.515	1880
17	0.503	1940
18	0.490	1990
19	0.478	2040
20	0.526	2090
21	0.556	1900
22	0.500	1800
23	0.450	2000
24	0.450	2220
25	0.450	2220
26	0.450	2220
27	0.450	2220
28	0.450	2220
29	0.450	2220
30	0.450	2220

Slow-down Timer Value

No.	Timer (ms)	Pulse (pps)
1	0.450	2220
2	0.450	2220
3	0.450	2220
4	0.450	2220
5	0.450	2220
6	0.450	2220
7	0.450	2220
8	0.500	2000
9	0.556	1800
10	0.526	1900
11	0.478	2090
12	0.490	2040
13	0.503	1990
14	0.515	1940
15	0.532	1880
16	0.549	1820
17	0.568	1760
18	0.588	1700
19	0.610	1640
20	0.645	1550
21	0.690	1450
22	0.741	1350
23	0.800	1250
24	0.870	1150
25	0.952	1050
26	1.053	950
27	1.176	850
28	1.429	700
29	1.818	550
30	2.500	400

3) Home Position Detector Drive Conditions

The motor drive should have the automatic startup using a 1-2 phase excitation when the home position detection is operating.

Timer (ms)	Pulse (pps)
1.499	667

4.4.4 Carriage Motor Drive Circuit Example

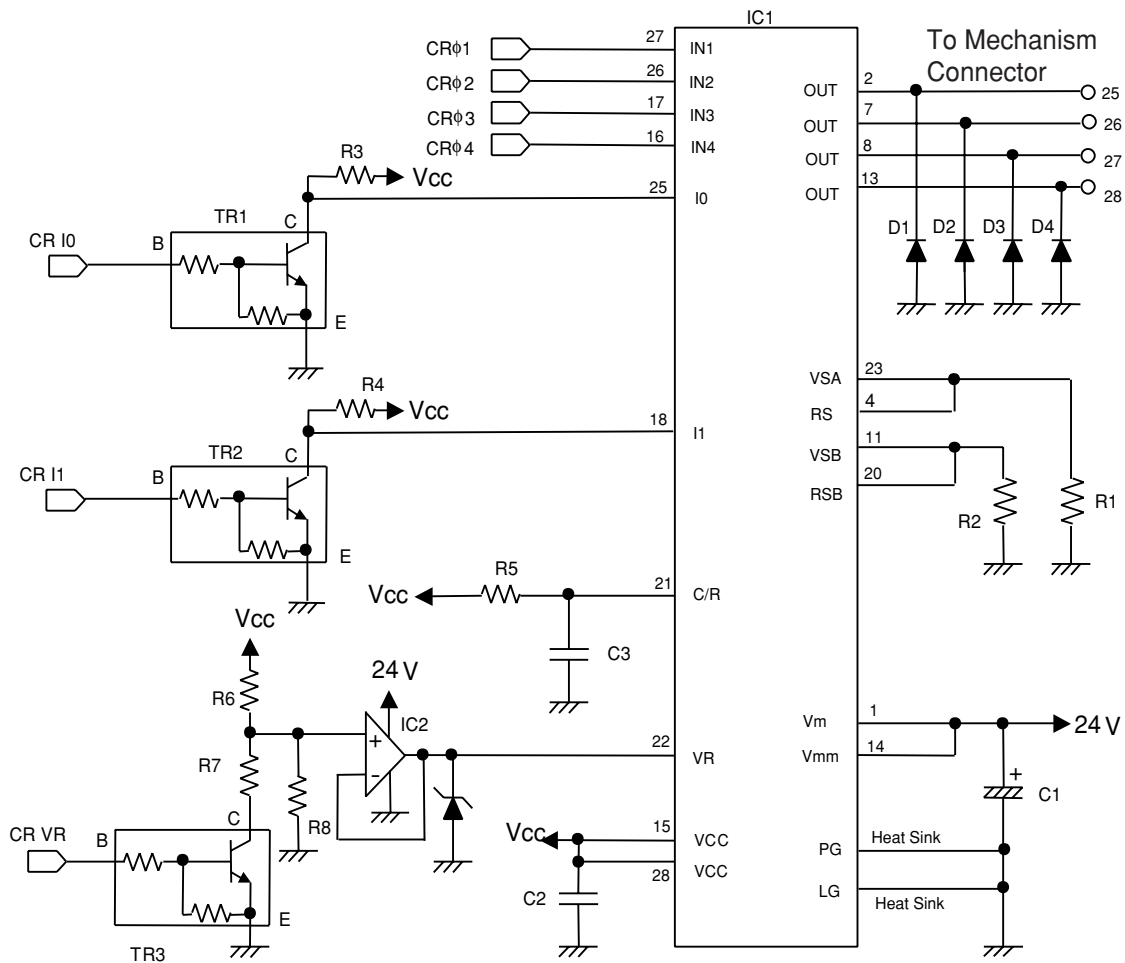

Fig. 4-10 Drive Circuit

Symbols	Specifications	Symbols	Specifications
IC1	MDT2003F (Shindengen)	R6	4.7 K Ω \pm 1%
IC2	UPC358 (NEC)	R7	1.0 K Ω \pm 1%
TR1	FA1A4P (NEC)	R8	Not mounted
TR2	FA1A4P (NEC)	C1	47 μ F
TR3	FA1A4P (NEC)	C2	0.022 μ F
R1	1.0 Ω \pm 1% 1W	C3	3900 pF
R2	1.0 Ω \pm 1% 1W	D1	D1FS4 (Shindengen)
R3	10 K Ω	D2	D1FS4 (Shindengen)
R4	10 K Ω	D3	D1FS4 (Shindengen)
R5	15 K Ω	D4	D1FS4 (Shindengen)

4.5 Home Position Detector

The MP500 series printers are equipped with a detector to detect the carriages home position. This detector is set by a micro switch to be closed when the carriage is at the home position and to be open when it is in any other position.

- 1) Types: Micro Switch
- 2) Types: MIC ELECTRONIC CORPORATION MPU10200MLA3
- 3) General Standards

Item	Rated Values	Units
Rated Voltage	5	VDC
Tolerable Current Range	0.1 to 100	mA
Operating Temperature Range	-15 to + 70	°C
Storage Temperature Range	-20 to + 75	°C

4) Example External Circuit

The numbers 5 and 6 in the external circuit diagram below refer to the pin numbers on the external connector.

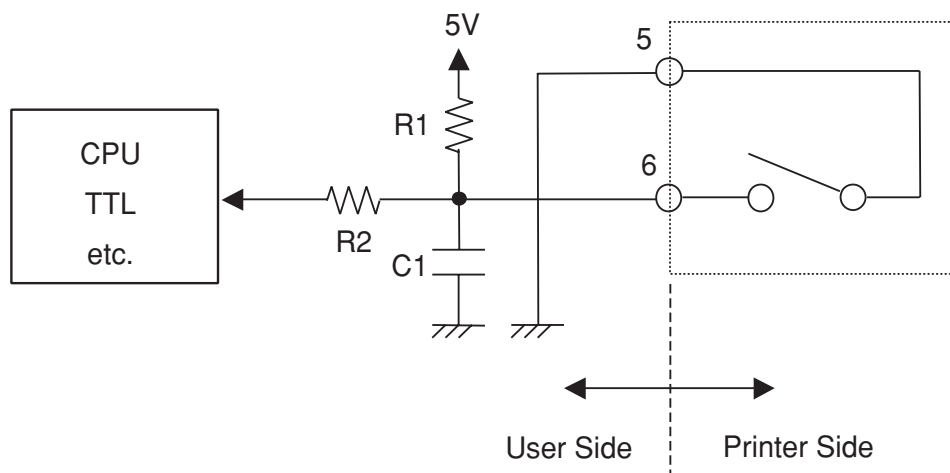

Fig. 4-9 Example External Circuit

Symbols	Numerical values
R1	10 KΩ
R2	4.7 KΩ
C1	0.022 μF

5) Home Position Detector Position

In the configuration of the external circuit according figure 4-9, the carriage presses the home position switch. When closed, the signal is High. Conversely, when open, the signal is Low.

See Fig. 4-10 for details regarding the positional relationships of the printing region and the side of the mechanism, based on the home position detector position.

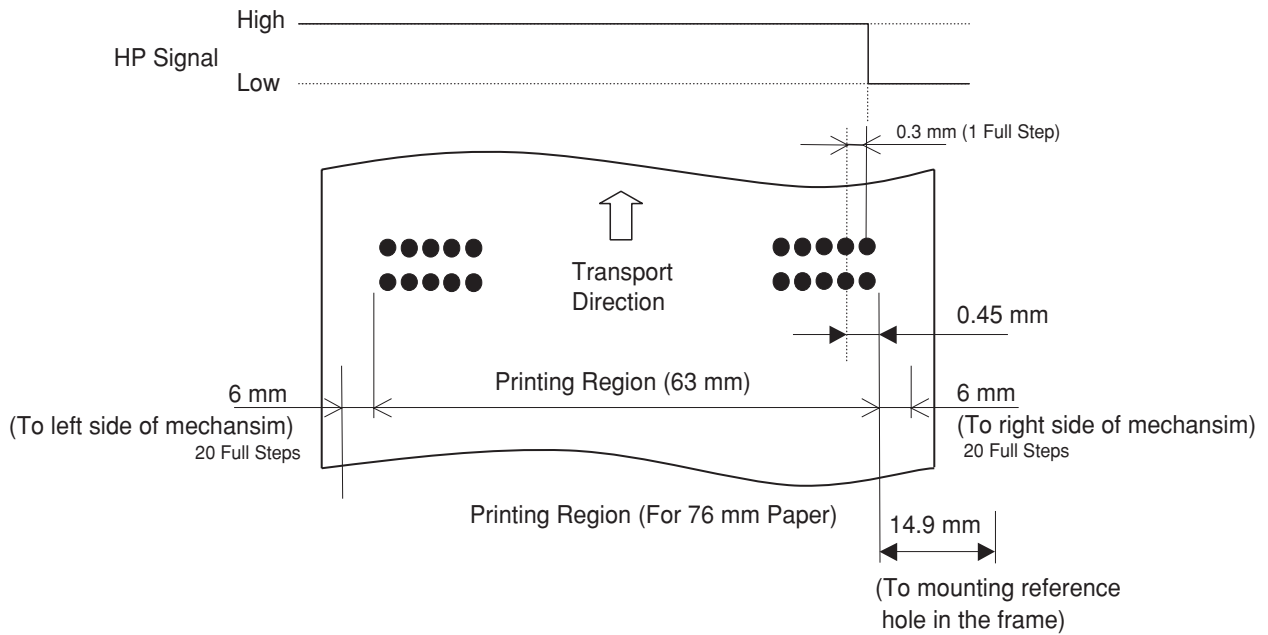
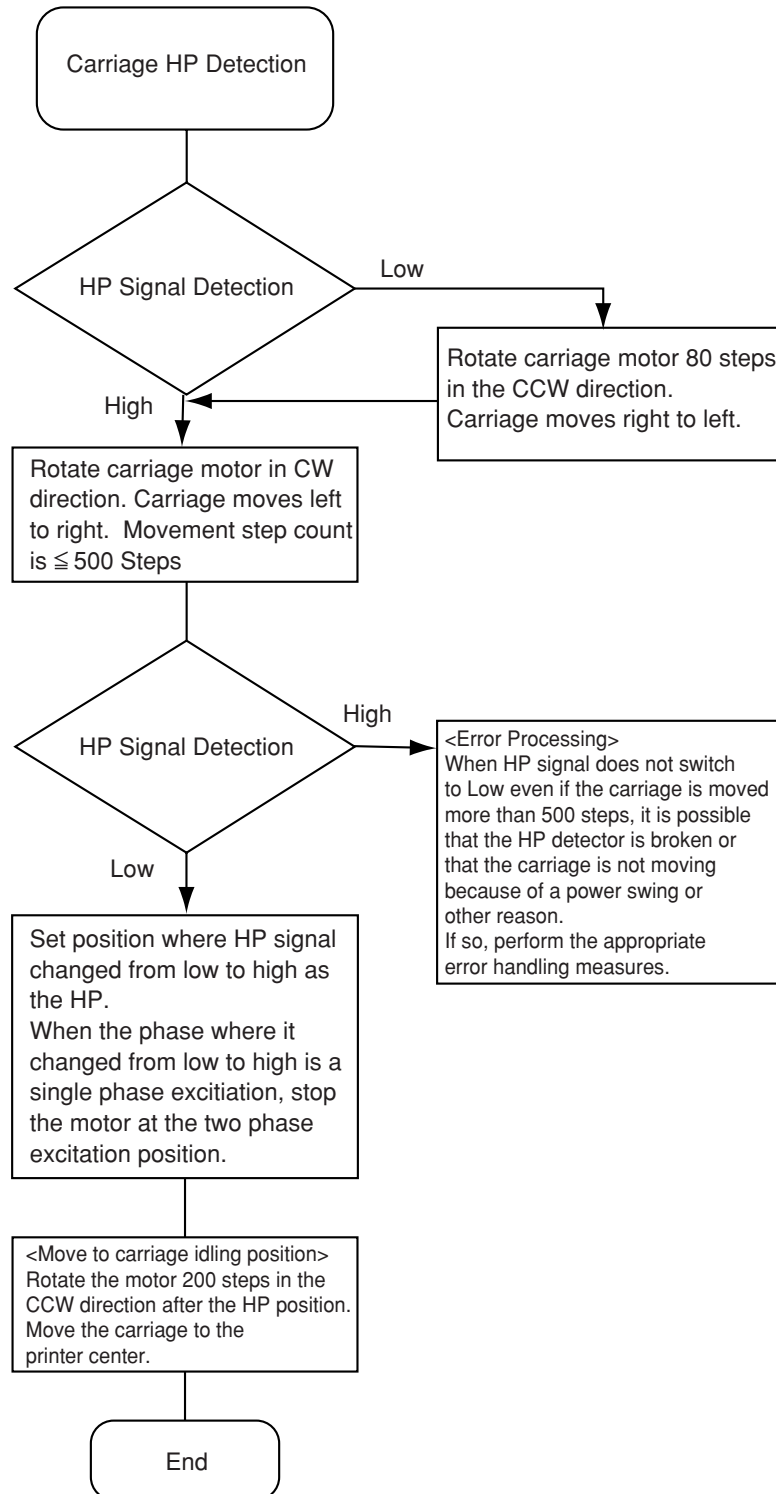

Fig. 4-10 Home Position Detector Position

6) Home Position Detector Operation

Perform the following carriage home position detection operation (HP detection operation) when there has been a carriage motor power swing when turning ON the power or there has been a paper jam. The carriage motor when performing a home position detection is driven automatically at 667 PPS (1-2 phase excitation, set current value: 0.485 A). The motor step counts in the flow chart are expressed in half steps.



7) Carriage Motor Power Swing Detection

The carriage motor is controlled in an open loop. Therefore, it will not detect that the printer motor is locked because of a foreign object being caught in the printer mechanisms. Continuing printing under such circumstances will damage related parts, such as the motor itself, so use the home position detector to periodically check for the possibility of motor power swings.

If a motor power swing occurs, stop printing right away.

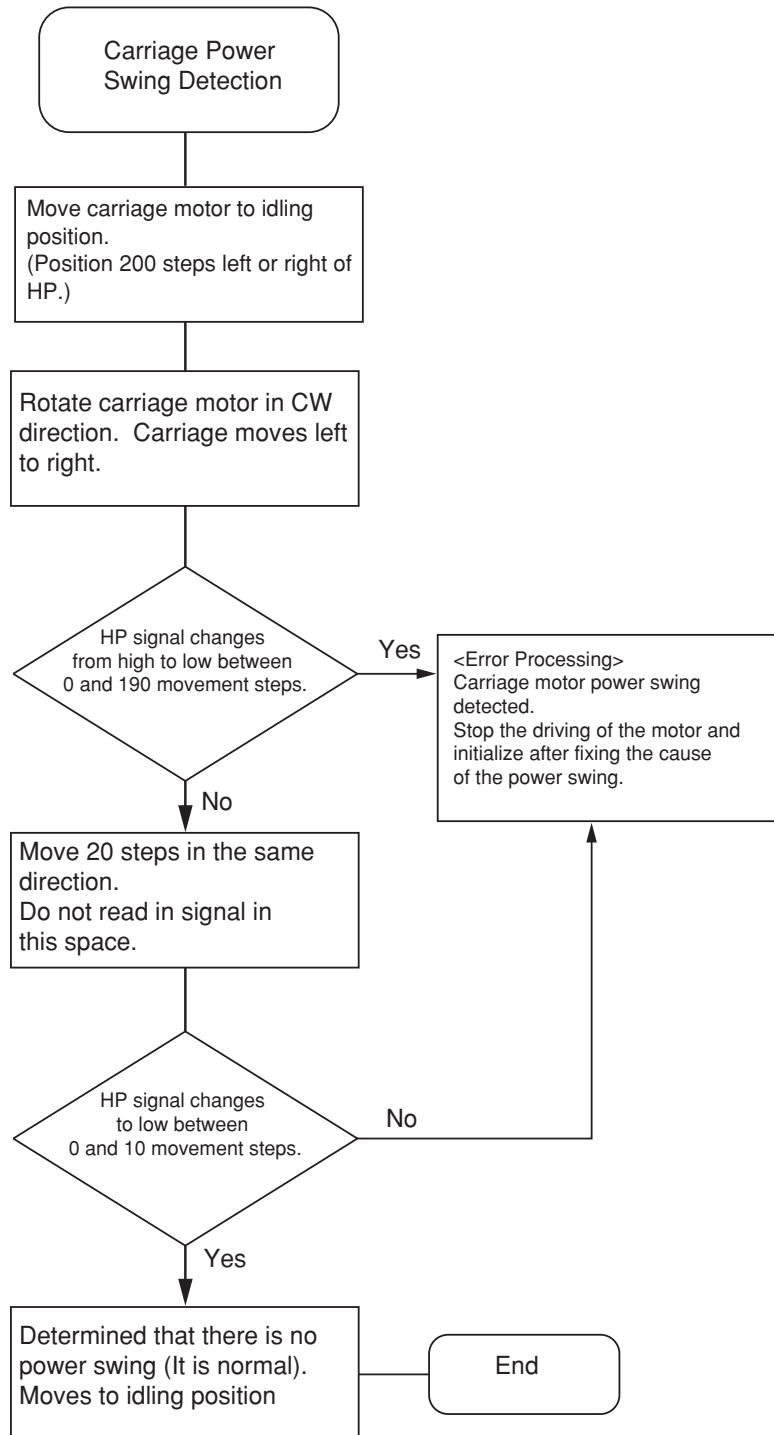

4.6 Timing Sequence

1) Chart

Set the paper feed to the space outside the carriage motor equivalent print region (decelerate -> hold -> accelerate).

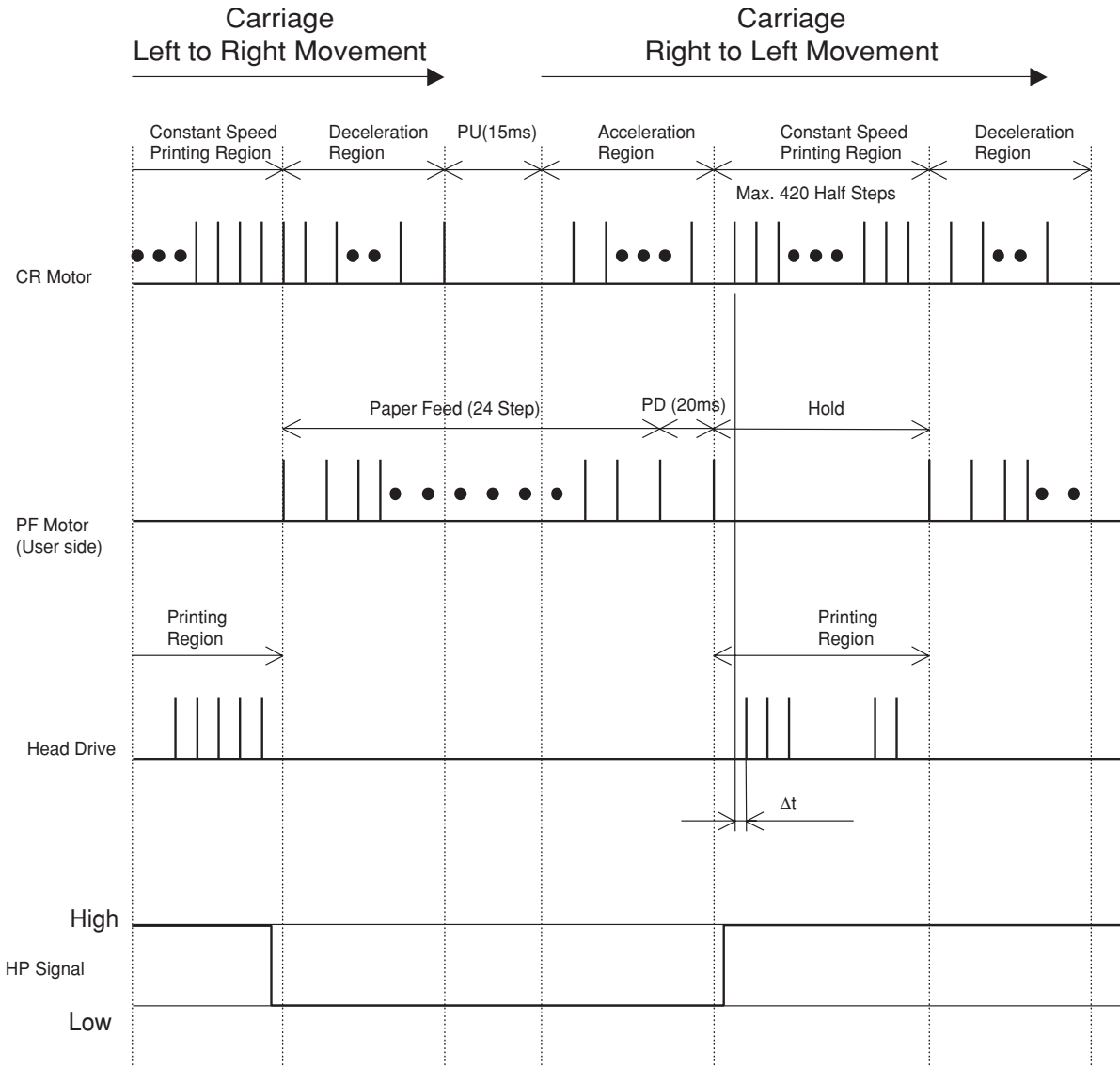

Fig. 4-13 Timing Sequence

Note:

When using bi-directional printing, offsetting will occur when printing by moving from the left to the right and by moving from the right to the left. This is because the carriage drive mechanism is physically shaken when driving, so there is always offset to the right side when printing from the right to the left, with printing from the left to the right as a reference. The amount of offset is fixed between 0.1 mm to 0.6 mm so offset the positions to print so that the positions on the lines above and below match when using bi-directional printing. To offset positions, delay the printing pulse Δt (see figure) when printing from right to left.

2) Dot Alignment in Bi-directional Printing

Very small gaps develop between each of the components that compose the carriage drive unit. For that reason, printing positions (called mis-positioning) become offset between printed lines in the carriage transport direction. Always correct that mis-positioning in the default state using the method described below.

The amount offset in default is approximately 1 to 1.5 dots ($\Delta t =$ approximately 900 to 1350 μs). There is also the possibility of the amount of mis-positioning developing to a maximum of 3 dots ($\Delta t = 2700 \mu s$) because of the ambient temperature of use and part wear-out after starting to use the printer. Therefore, it is recommended to correct this mis-positioning according to your needs for high quality Chinese character printing and graphics in bi-directional printing.

<Adjustment of Dot Alignment>

See Fig. 4-13 Timing Sequence.

To correct mis-positioning, the head drive timing when the head is transported from the right to the left is delayed Δt .

Δt should be corrected to a maximum of 3 dots ($\Delta t = 2700 \mu s$).

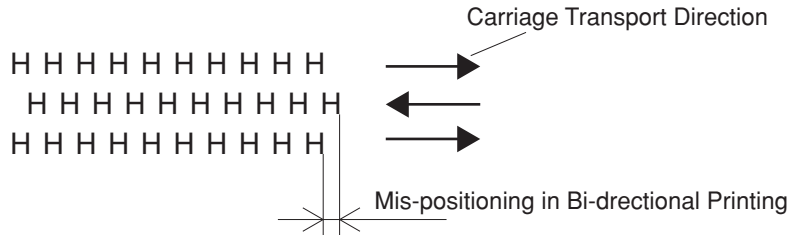

[Example Adjustment Using Test Printing (For Reference)]

At right is an example pattern when determining the mis-positioning adjustment value Δt using a test print. In one block with the same correction value Δt using bi-directional printing to print the letter 'H,' the Δt for the first block is changed to print 225 μs (1/4 dots), and the second block is changed 225 μs to print 450 μs . The Δt for the 12th block is 2700 μs (3 dots).

After the test print, visually find the blocks that match and store that Δt value equivalent to those blocks in the non-volatile memory, then print again using those numerical values.

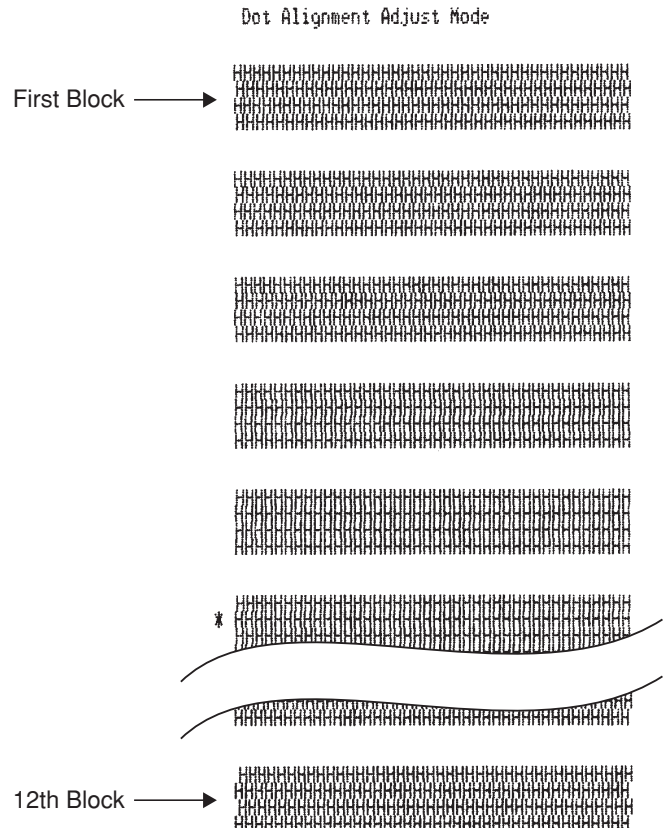

4.7 Connector Wiring Diagram

1) Connector Specifications

The MP500N series printers are standardly equipped with connector for external connections. To connect the control card and MP500N, use an FFC or FPC cable that meets the following connector specifications.

- Types: FFC/PFC Connectors
- Serial Number: Nippon FCI Co., Ltd.: HLEM 28 R-1
- Specifications: 1.25 mm pitch, 28 poles
- Connecting Point: Connector Upper Surface

2) Connector Pin Numbers

Pin No.	Signal Name	Function
1	N. C.	Not Used
2	N. C.	Not Used
3	N. C.	Not Used
4	N. C.	Not Used
5	S-GND	Signal Ground
6	HP-sig	Carriage Home Position Signal
7	HD #4	Print Head #4 Pin
8	HD #6	Print Head #6 Pin
9	HD #8	Print Head #8 Pin
10	HD CMN	Print Head Common Pin
11	HD #9	Print Head #9 Pin
12	HD #5	Print Head #5 Pin
13	HD #7	Print Head #7 Pin
14	HD CMN	Print Head Common Pin
15	HD #3	Print Head #3 Pin
16	HD TH	Print Head Thermistor
17	HD TH	Print Head Thermistor
18	HD CMN	Print Head Common Pin
19	HD #2	Print Head #2 Pin
20	HD #1	Print Head #1 Pin
21	N. C.	Not Used
22	N. C.	Not Used
23	N. C.	Not Used
24	N. C.	Not Used
25	CR _1	Carriage Motor Drive Signal (A Phase)
26	CR _2	Carriage Motor Drive Signal (/A Phase)
27	CR _3	Carriage Motor Drive Signal (B Phase)
28	CR _4	Carriage Motor Drive Signal (/B Phase)

3) Terminal Card Wiring Diagram

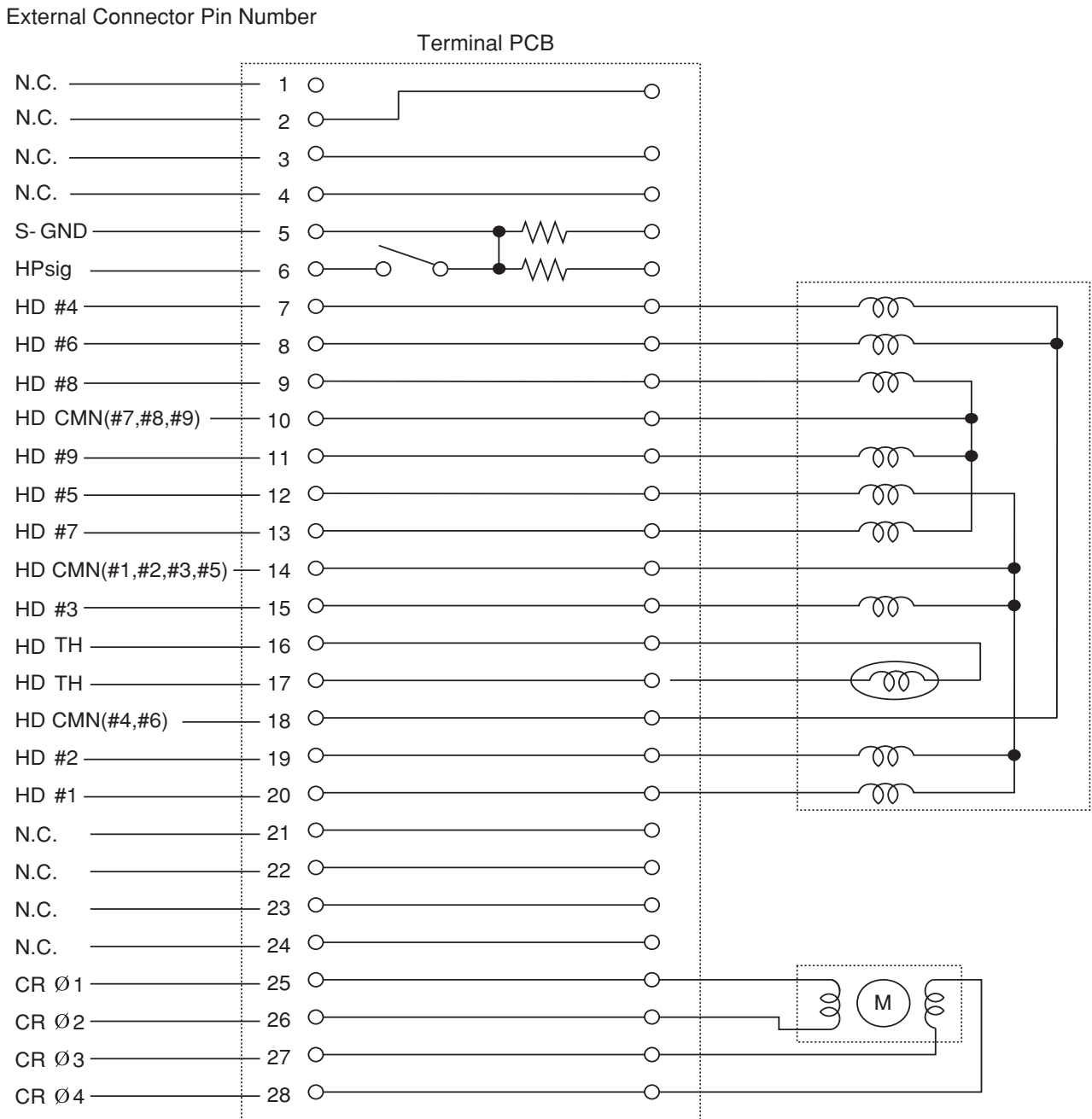

Fig. 4-14 Wiring Diagram

4.8 Ribbon Cassette Specifications

- | | |
|-----------------------|---|
| 1) Types: | Dedicated ribbon cassette RC200B |
| 2) Colors: | Black (Single Color) |
| 3) Ribbon Material: | Nylon 66 |
| 4) Ribbon Dimensions: | Width: 13 mm |
| 5) External Shape: | Width: 144.4 mm, Depth: 65 mm, Height: 26.7 mm (max.) |
| 6) Life: | 1.2 million characters |

<Conditions>

- Printing Characters: 7 x 9 Fonts
- Print Patterns: ASCII Continuous Printing (Average 2 dots/head pin per 1 character)

Note:

There is the possibility of problems such as printer failure may occur if you use a ribbon cassette other than the recommended types.

Such problems are not under warrantee.

Using an ink ribbon beyond its normal use life will notable shorten the life of the mechanism and print head.

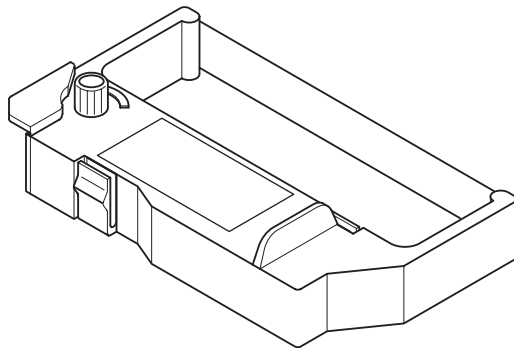

Fig. 4-15 Ribbon Cassette

4.9 Setting the Head Gap

The printer mechanism, when shipped from the factory, is aligned to 8 ± 0.3 mm distance between the reference line that connects the mounting hole on the bottom of the printer frame and the oblong mounting hole, and the head needle tip (see figure below). However, because the distance has a margin of ± 0.3 mm, check that the head gap is within a reasonable gap of 0.45 to 0.50 mm when mounting the printer mechanism to a device.

If the head gap is inappropriate, move the adjust bushings mounting positions on the left and right side of the printer mechanism to readjust the head gap.

Moving the adjust bushings to the negative side decreases the head gap. Conversely, moving to the positive side increases the gap. The head gap varies approximately $17 \mu\text{m}$ in reference to the one groove in the leading end of the adjust bushing.

Always tighten the fastening screw after adjusting the head gap. To prevent loosening of the screw later, it is recommended that a screw-lock product be dispensed to the screw.

Note:

- 1) Head gap is the distance of the direct space between the needle tip on the print head and the platen.
- 2) Platen planarity in the printing region should be max. 0.03 (including unevenness).
- 3) use a fixed platen.
- 4) If the head gap is not within the appropriate range, print quality, printer functions and head life can all be mal-affected. Measure the head gap value for proper adjustment when mounting the printer mechanism. Using a thickness gauge makes measurement of the head gap easier.
- 5) The head gap must be appropriate within the entire print range.
- 6) If a metal plate comprises the platen, its thickness should be min. 2 mm.

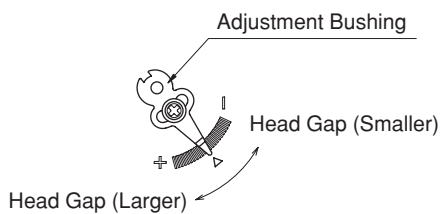

Fig. 4-16 Head Gap Adjustment Position

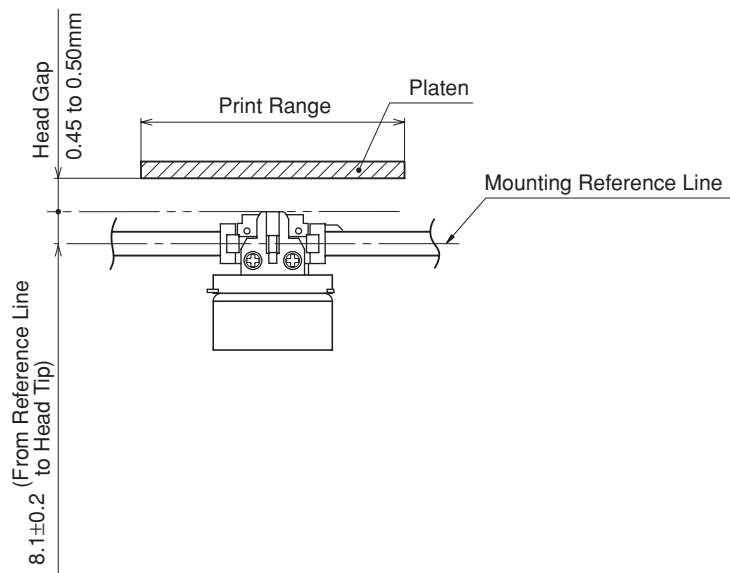

Fig. 4-17 Mechanism Mounting Position and Platen Distance

5. PRECAUTIONS WHEN MOUNTING THE PRINTER

5.1 Printer External Dimensions and Mounting the Printer

See Fig. 5-2. (next page)

Use the reference mounting hole on the bottom of the printer frame and the oblong reference mounting hole (on the user side) to position the printer. When fastening the printer to the mounting base, use the M3 screws from the mounting base side to mount the four places on the frame bottom to mount. Use the printer fastening screws as ground screws for static electricity.

After fastening the printer to the mounting base, always set the head gap as described in section 4.9 so it will have the appropriate head gap.

5.2 Space for Mounting Removing the Ribbon Cassette

See Fig. 5-1 to ensure plenty of space around the ribbon cassette to facilitate its easy mounting and removal.

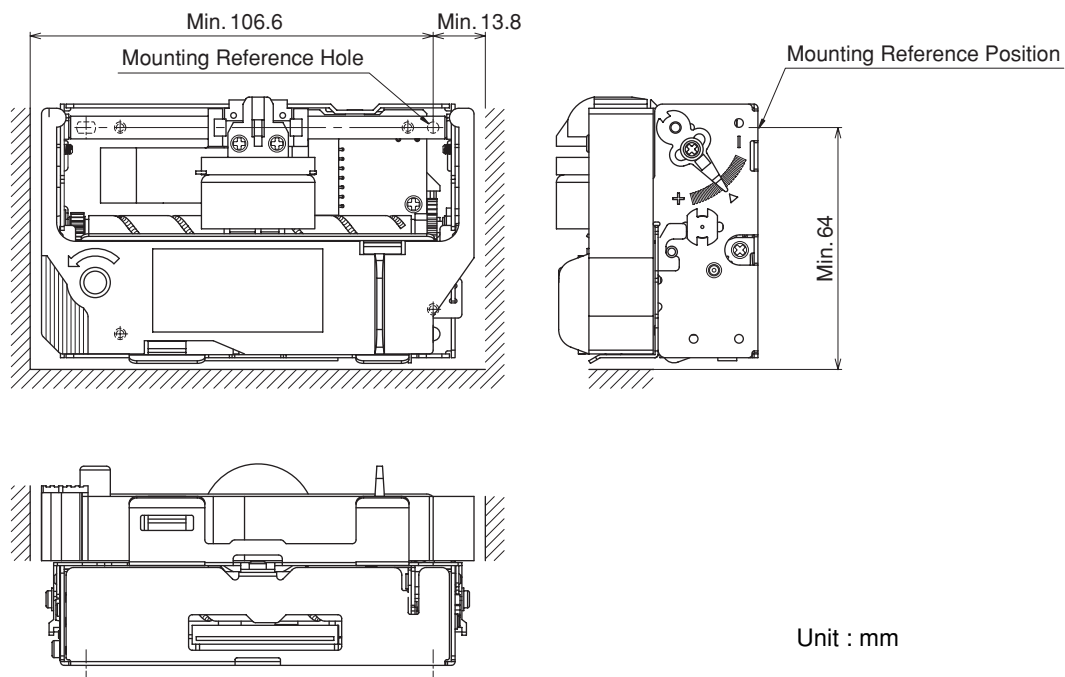

Fig. 5-1 Space for Mounting Removing the Ribbon Cassette

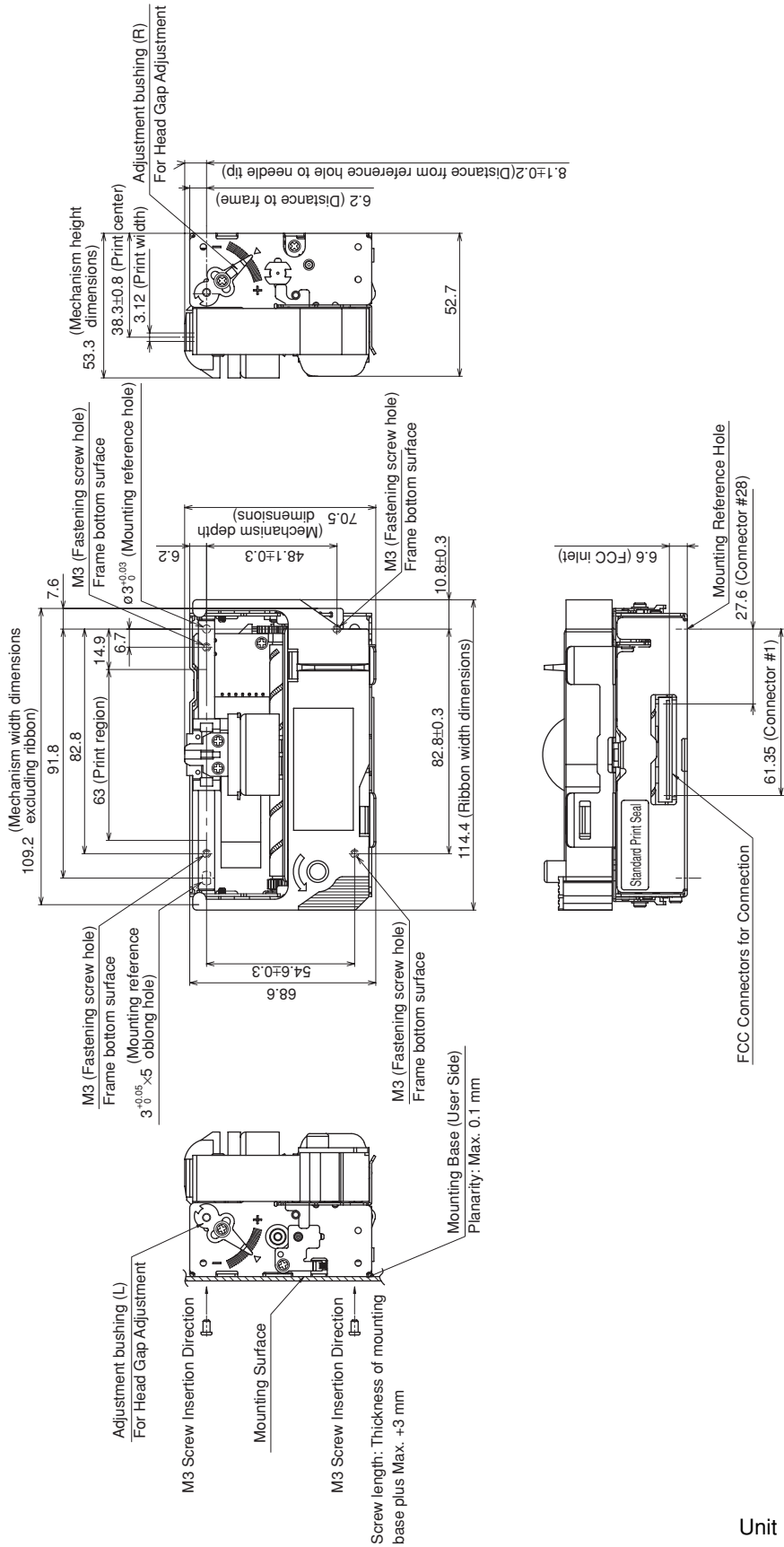

Fig. 5-2 External Dimension Drawing

5.3 Head Vicinity

Design the outer casing of the printer so that no static electricity is discharged to the print head.

5.4. Precautions for Designing the Paper Path

When the ribbon and paper come into contact in the paper path between the head and platen (on the user side), the printer becomes dirty. Design the paper path so that the paper does not swell to the user side to reduce the dirt. Also, accompanying the movement of the head and ribbon, the print quality can be affected when the paper moves, so design the paper path accordingly.

- 1) Dirt (smudging) will be generated in the horizontal direction during printing.
- 2) Dirt will be generated at an angle of approximately 10 mm to the paper surface, opposing the head, while idling.

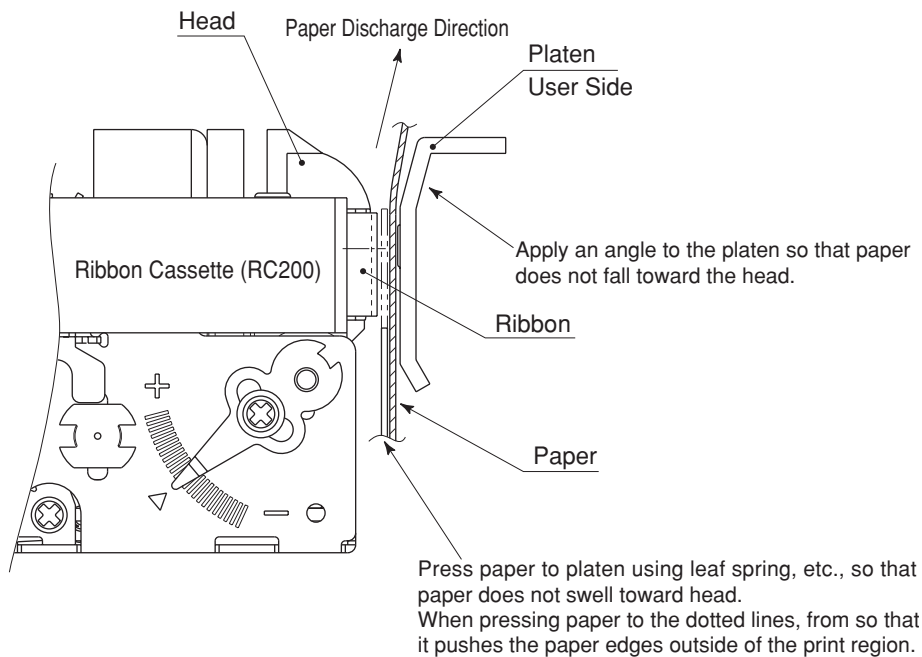

Fig. 5-3 Precautions for Designing the Paper Path

5.5. Precautions When Controlling the Printer

- 1) The printer drive voltage should be max. 26.4 VDC (print head and carriage motor)
- 2) Use the home position sensor within the tolerable current.
- 3) Use the following safety precautions for the print head and carriage motor.
 - Printer Head Never energize over 390 μ s for any reason, include software runaway.
 - Carriage Motor Never energize over a maximum 2 seconds to the same phase for any reason, include software runaway.
(*Excluding holding time)

6. OTHER PRECAUTIONS

- 1) Securely set the paper before printing.
- 2) The print head and carriage motor can become very hot depending on the printing conditions. Be careful when opening the outer case. Also, affix a warning seal that meets safety standards to the upper surface of the print head.
- 3) Do not store or use the printer in locations that are dusty, oily or exposed to metallic dust.
- 4) Use a soft cloth or a brush to clean away dirt and dust from the printer. Also, you can wipe with a soft cloth lightly dampened with alcohol.
- 5) Do not apply an unnecessary amount of force to the printer. This can disfigure the frame and lead to the printer not functioning properly.
- 6) Avoid sudden changes even if the ambient temperature and humidity are within standard conditions. Allow the printer to sit in its new environment for at least 30 minutes before use in the event there has been a sudden change.
- 7) The printer uses plated steel so cut surfaces have not been treated.
- 8) Do not use the printer in an environment where condensation has formed.



**ELECTRONIC PRODUCTS DIVISION
STAR MICRONICS CO., LTD.**

536 Shimizunanatsushinya,
Shizuoka, 424-0066 Japan
Tel : (int+81)-54-347-2163 (English)
Fax: (int+81)-54-347-0409

**OVERSEAS SUBSIDIARY COMPANIES
STAR MICRONICS AMERICA, INC.**

1150 King Georges Post Road, Edison,
NJ 08837-3729 U.S.A.
Tel : (int+1)-732-623-5555
Fax: (int+1)-732-623-5590
<http://www.starmicronics.com>

STAR MICRONICS EUROPE LTD.

Star House, Peregrine Business
Park, Gomm Road, High Wycombe,
Bucks, HP13 7DL, U.K.
Tel : (int+44)-1494-471111
Fax: (int+44)-1494-473333
<http://www.starmicronics.co.uk>

STAR MICRONICS ASIA LTD.

Rm. 1901-5, 19/F., Enterprise Square Two,
3 Sheung Yuet Road, Kowloon Bay,
Hong Kong
Tel : (int+852)-2796-2727
Fax: (int+852)-2799-9344
<http://www.starhkg.com.hk>

Please access the following URL
<http://www.star-m.jp/eng/dl/dl02.htm>
for the latest revision of the manual.

Distributed by